

## BAND SAWS SCIES À OS

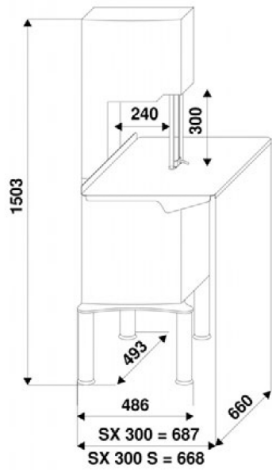

**SX300**

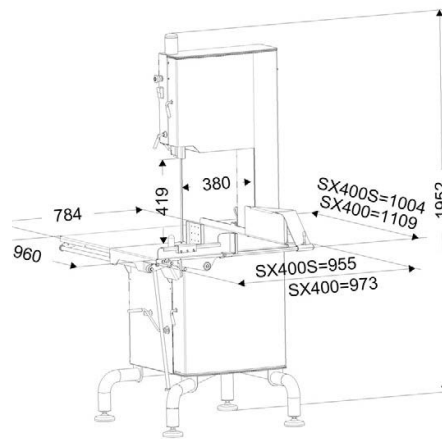

**SX375**

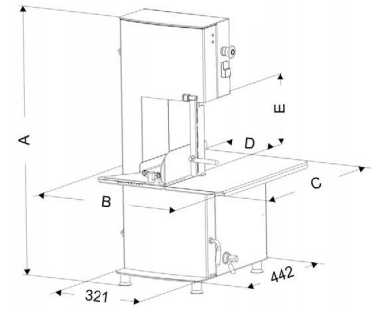

	A	B	C	D	E
SX200	874	510	571	188	245
SX220	921	529	558	194	230

## STANDARD MINCERS HACHOIRS STANDARD

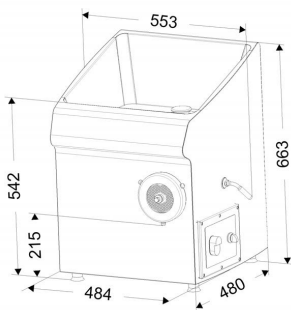

**TX98**

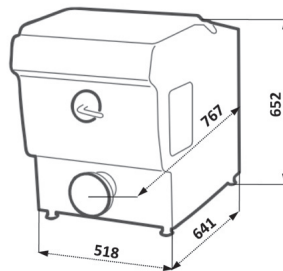

**TX98 MINIMIX TYPE 35**

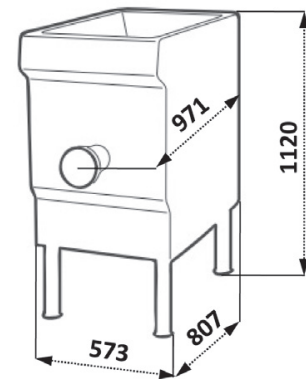

**TX98 COMPACT**

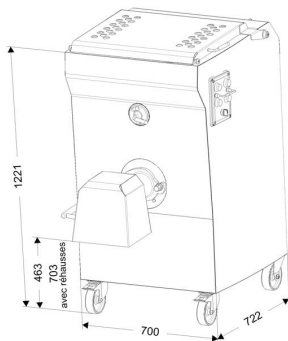

**TX32 | TX114**

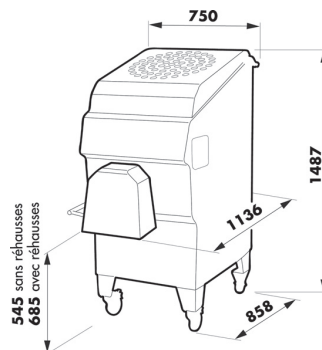

**TX130**

## REFRIGERATED MINCERS HACHOIRS RÉFRIGÉRÉ

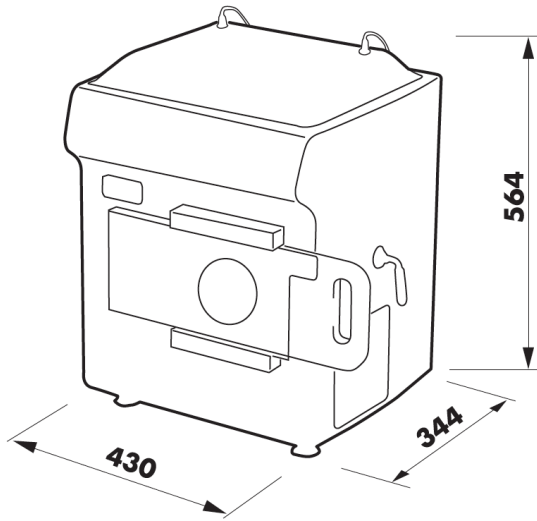

**ZIRCON**

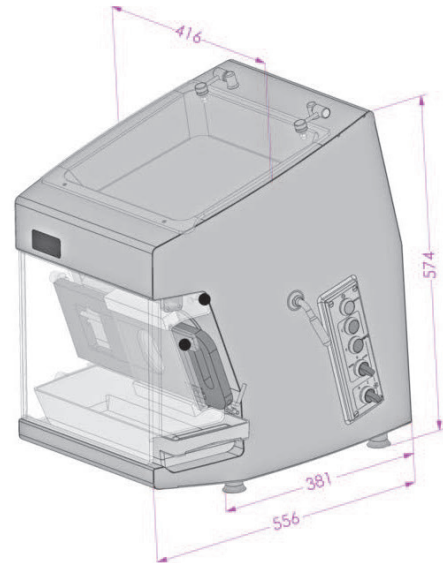

**SETNA**

## TARTARE/ STRIPS TTARTARE/ BANDES

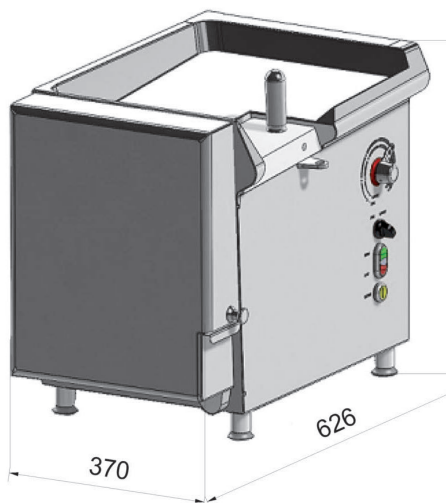

**PRECICUT 2D**

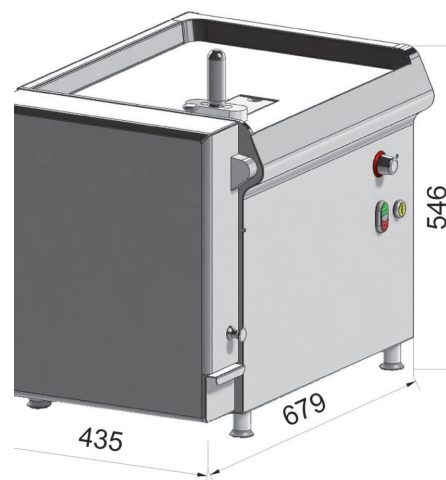

**PRECICUT 3D**

## CUTTERS CUTTERS

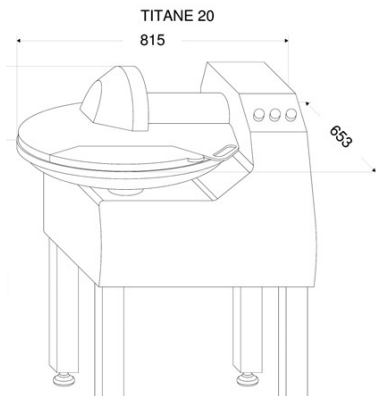

**TITANE 20**

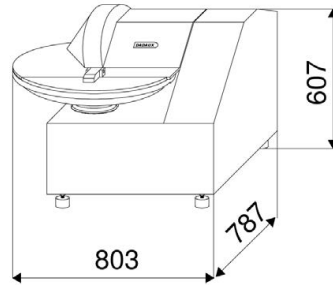

**TITANE 23**

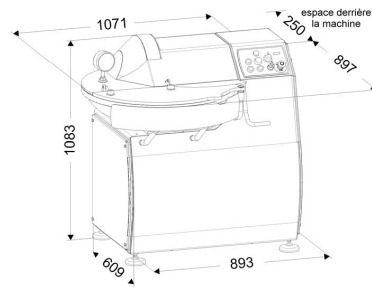

**TITANE 40-2 | 45V**

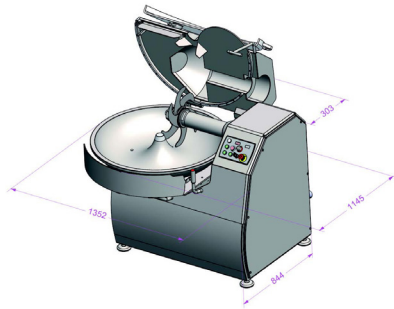

**TITANE 80V**

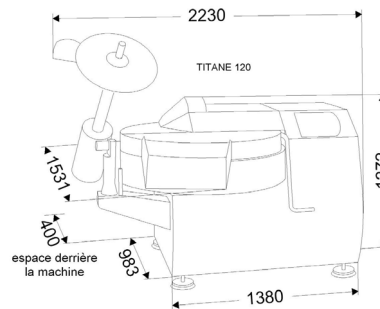

**TITANE 120V**

## CHOP CUTTERS TRANCHEURS À CÔTELETTE

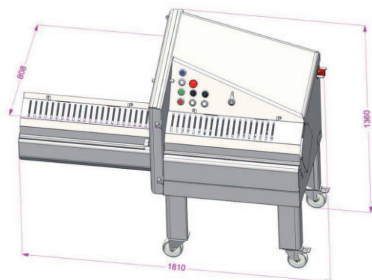

**ICONE 700**

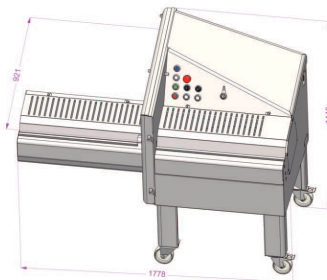

**ICONE 700 BACON**

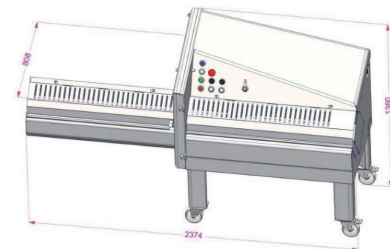

**ICONE 1100**

Dimensions shown in millimeters, multiply by 0.039 for sizing in inches  
 Dimensions indiquées en millimètres, multipliers par 0.039 pour les dimensions en pouces

## CUBER CUBEUSE

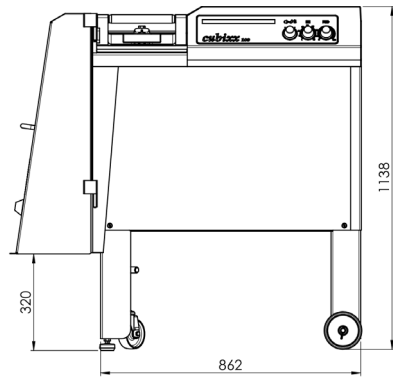

**CUBIXX 100**

## MIXERS MELANGEURS

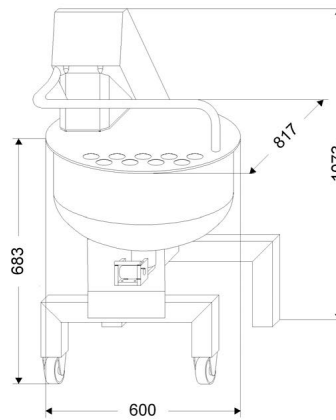

**PMX60 | PMX60 CM**

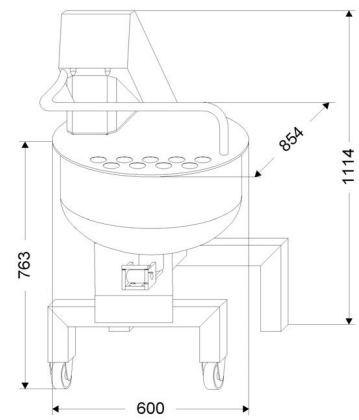

**PMX90 | PMX90 CM**

## SLICERS TRANCHEURS

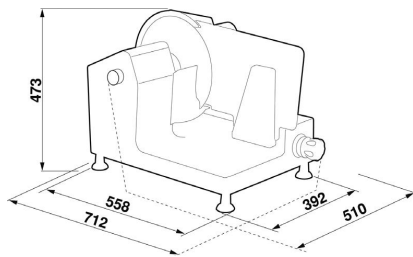

**MAJOR SLICE 300V**

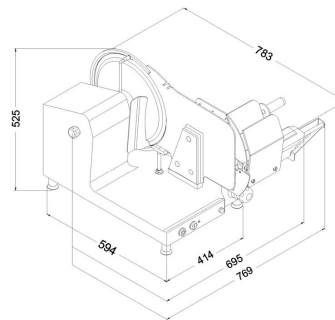

**MAJOR SLICE 350V**

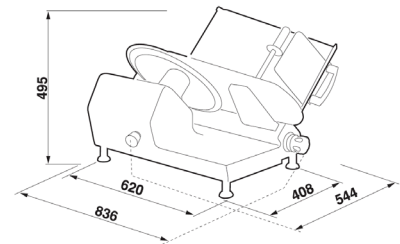

**MAJOR SLICE 350**

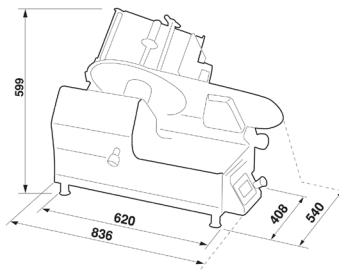

**MAJOR SLICE 350 SEMI  
AUTO**

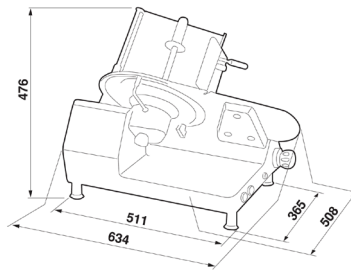

**GRAVINOX 300**

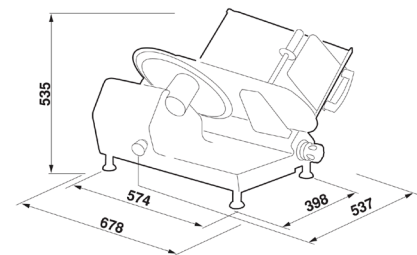

**GRAVINOX 350**

**SAUSAGE STUFFERS (MANUAL & HYDRAULIC) POUSSOIRS SAUCISSON (MANUEL & HYDRAULIQUE)**

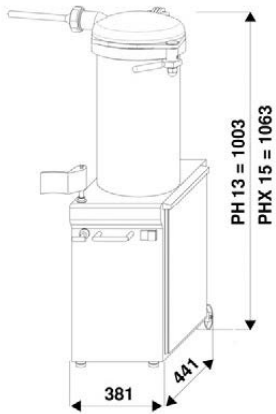

**PH13 | PHX15**

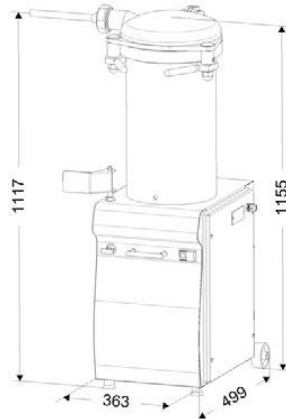

**PHX25**

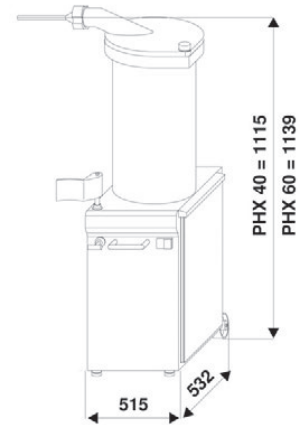

**PHX40 | PHX60**

**SEMI-AUTOMATIC SAUSAGE STUFFERS POUSSOIRS SAUCISSON SEMI-AUTOMATIQUE**

**PEELERS/ SKINNERS ÉPLUCHEUSES/ DÉCOUENNEUSES**

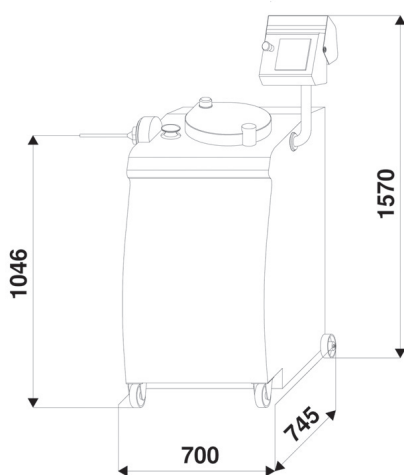

**TORSADO**

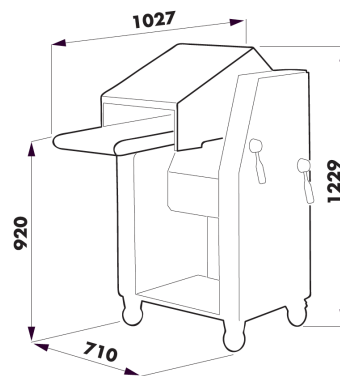

**DC460 | DC500**

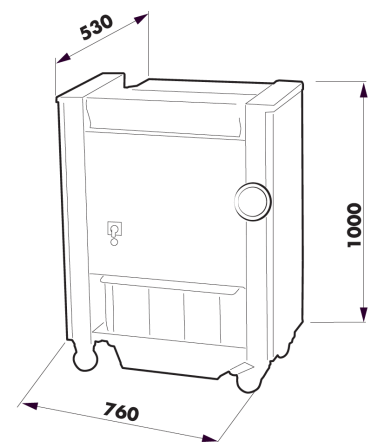

**ADW400**