

## Packaged Product Self-Facers



## Keep Products Freshly Faced Continuously

Give your produce department a fresh look with Carlson AirFlo's packaged product Self-Facers. Our Self-Facers are ideal for pre-packaged presentations achieving visual impact, faster product rotation and turnover, and increased impulse sales. **Outshine. Outsell. Outperform.**



P 514.336.9191 or 877.336.9191 info@franesse.ca

© 2015 All rights reserved. Carlson AirFlo is a registered trademark of Stein Industries, Inc. D112.112015



## Benefits & Features:

### Product Self-Facers

Self facers are an excellent solution for presenting pre-packaged salad and vegetable displays, bagged cheese, seeds and nuts, boxed dips, frozen food products, trayed protein products such as tofu and meats and many more items. Reduce the amount of inventory required to create a full look on your mezzanine shelves.

- **Visual Impact:** Create beautifully uniform, well organized, continuously and perfectly faced sections with minimal inventory
- **Increase Sales:** Self Facing system is proven to increase impulse sales of all packaged goods.
- **Save Labor:** Eliminates manually facing of product
- **Improve Rotation:** Easier to rotate product, resulting in reduced shrink and increased profits.
- **Heavy Duty:** Extruded plastic and stainless steel coil spring for life long dependability
- **Multiple Sizes:** Several options & solutions available for a variety of applications

## Shelf Options:

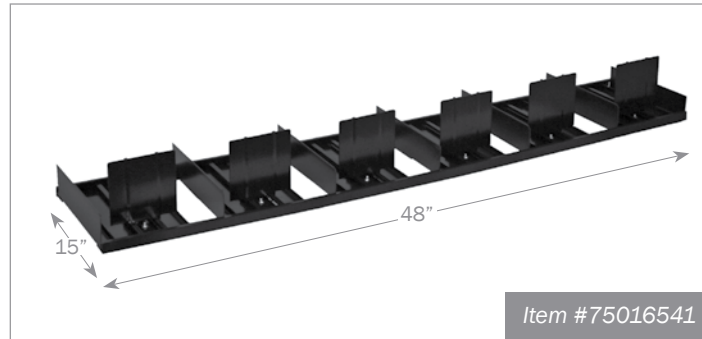

Part Number	Description
75015941	6 Facing x 10"D x 48"W Self Facing Unit
75016341	6 Facing x 13"D x 48"W Self Facing Unit
75016541	6 Facing x 15"D x 48"W Self Facing Unit
75016741	6 Facing x 17"D x 48"W Self Facing Unit
75016841	6 Facing x 18"D x 48"W Self Facing Unit

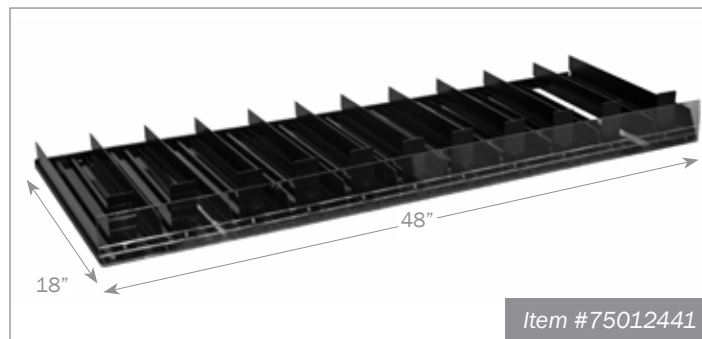

Part Number	Description
75011841	11 Facing x 12"D x 48"W Self Facing Unit
75011941	11 Facing x 13"D x 48"W Self Facing Unit
75012141	11 Facing x 15"D x 48"W Self Facing Unit
75012441	11 Facing x 18"D x 48"W Self Facing Unit
75012541	11 Facing x 22"D x 48"W Self Facing Unit

## Shelf Options Continued:



Wire Self Facer - 14"D x 5"W x 2"T  
Part #: 75032221

### Wire Self Facer

- Adjustable width 5 1/4" - 10"W
- Affordable Design



ABS Tray Self Facer - 14"D x 5"W x 2"T  
Part #: 75029441

### ABS Tray Self Facer

- May be customized with brand

## Rear Hanging Options:

### AirBar Self Facer System

Designed specifically to integrate seamlessly into an existing merchandised system or completely transform an entire area cost effectively and efficiently. AirBar Self Facing System requires Mounting Bar Kit for installation.



Adjustable flat and curved front self facers for AirBar System. 15", 17", 19" Adjustable Depth and Width Self Facer w/ PTM & Fence. Flat Part #: 75024941 and Curved Part #: 75022041

### AirGrid Self Facer System

Available in Curved Front Self Facers for Grid System.

- Adjustable depths of 15", 17", and 19".
- Width adjusts from 5 3/8 – 12.5"



Adjustable Self Facer for AirGrid System 15", 17", 19" Adjustable Depth and Width Self Facer w/ PTM & Fence Part #: 75022141  
48"W x 9"H AirGrid Wire Wall Kit - Part #: 250171  
48"W x 13"H AirGrid Wire Wall Kit - Part #: 250170  
48"W x 22"H AirGrid Wire WallKit - Part #: 250169

# Benefits and Features:

## NEW Adjustable Gravity Feed

Keeps products faced and organized in straight lines to create a uniform, abundant looking display. The Adjustable Gravity Feed surface provides a low coefficient of friction allowing product to easily slide forward due to angle of shelf.

- **Visual Impact:** Create beautiful, clean, well organized, continuously abundant displays with minimal inventory
- **Increase Sales:** Self facing systems are proven to increase impulse sales of packaged goods.
- **Save Labor:** Eliminates manually facing of product
- **Improve Rotation:** Easier to rotate product, resulting in reduced shrink and increased profits.
- **Category Management:** Keeps product organized and aligned
- **More Options:** Now available for ALL AirFlo CTM shelves and most other shelving
- **One Divider works for all:** Dividers are designed to be interchangeable with all AirFlo Gravity Feed Kits, and now with telescopic properties for most depth shelves. Conveniently repositions and easily removable.
- **AirFlo CTM & Gravity Feed:** Ability to control speed by designating 5°, 10°, 20°, and 30° down.



Adjustable Gravity Feed Kit combined with an AirFlo CTM shelf you have the ability to go 5°, 10°, 20° or 30° down



## Adjustable Gravity Feed Kit with AirFlo CTM Shelf

Part Number	Description
C4C13	13" CTM Shelf and Adjustable 16 Divider Gravity Feed Kit. Various fence heights also available.
C4C15	15" CTM Shelf and Adjustable 16 Divider Gravity Feed Kit. Various fence heights also available.
C4C17	17" CTM Shelf and Adjustable 16 Divider Gravity Feed Kit. Various fence heights also available.
C4C19	19" CTM Shelf and Adjustable 16 Divider Gravity Feed Kit. Various fence heights also available.
C4C21	21" CTM Shelf and Adjustable 16 Divider Gravity Feed Kit. Various fence heights also available.

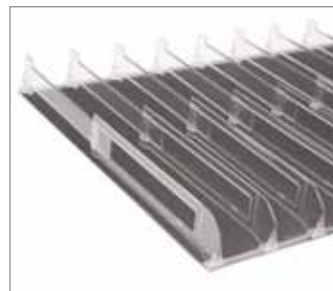

Gravity Feed Kit includes 2 rails, 16 clear adjustable dividers and Gravity Feed Surface.

## Adjustable Gravity Feed Kit

Part Number	Description
250570	13" Adjustable 16 Divider Gravity Feed Kit.
250571	15" Adjustable 16 Divider Gravity Feed Kit.
250572	17" Adjustable 16 Divider Gravity Feed Kit.
250573	19" Adjustable 16 Divider Gravity Feed Kit.
250574	21" Adjustable 16 Divider Gravity Feed Kit.

